

S3000™ 1" Cordless Aluminum Blinds

PRODUCT SPECIFICATIONS

Headrail shall be 1" high x 1-1/2" wide x .025" thick steel valance-free design with a curved front profile, rolled edges at the top, and a lightblocking lip at the lower back side. The steel finishing process includes phosphate treatment for corrosion resistance, a chrome-free sealer, a low hazardous air pollutants (HAP) urethane primer, and a topcoat of low HAP, polyester-baked enamel.

Tilter shall be made of injection-molded thermoplastics for smooth low-friction operation and shall incorporate a clutch mechanism to prevent damage due to overtilting.

Tilt Rod shall be electro-zinc coated solid steel measuring 1/4" square.

Tilt Wand shall be clear polycarbonate with a hexagonal cross section measuring approximately 1/4" diameter and attached to the tilter shaft by means of a spring clip for easy removal.

Drum and Cradles shall be low-friction thermoplastic and provided for each ladder.

Installation Brackets shall be top loading, zinc-plated steel with a snap-in design for easy installation.

Braided Ladder shall be made of 100% polyester yarn, incorporating two extra-strength rungs per ladder for slat support. Standard ladder spacing shall be 21.5 mm.

Slats shall be 5000 series cold-rolled aluminum containing the maximum allowable recycled content to produce a high-strength and corrosion-resistant flexible product. Slats shall be nominally 1" wide x .006" thick and processed to provide a smooth, hard, less porous surface with antistatic performance to repel dust. Slats shall be treated with a topcoat of low HAP polyester-baked enamel.

Bottomrail shall be a completely enclosed tubular shape made of phosphate-treated steel for corrosion resistance and finished with a chrome-free sealer, low HAP urethane primer, and a topcoat of low HAP, polyester-baked enamel. Bottomrail shall measure .025" thick.

OPTIONS

- .008" thick slat
- Inverted slat for daylighting
- Hidden Holes privacy and lightblocking slat with 18 mm spacing
- Tilt limiter
- Ring tilt
- Extension brackets
- Hold down brackets

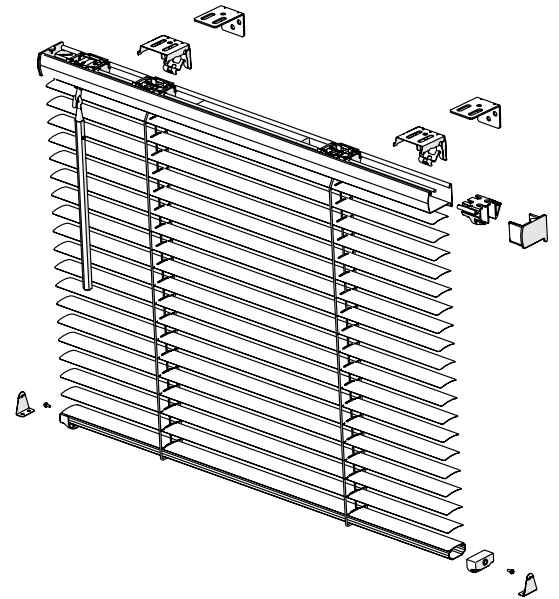

PRODUCT FEATURES AND BENEFITS

- 1" x 1-1/2" headrail with integrated valance for clean, finished look
- Lightblocking lip on headrail eliminates light leakage and slats tilt to any position to control light and privacy
- Snap-in hidden brackets and enclosed bottomrail
- Antistatic performance to repel dust
- Low HAP, low VOC paint process
- Slats meet NFPA 701
- Limited lifetime warranty